

HYDROGEN

VÁLVULAS Y RACORES
VALVES & FITTINGS
VÀLVULES I CONNEXIONS

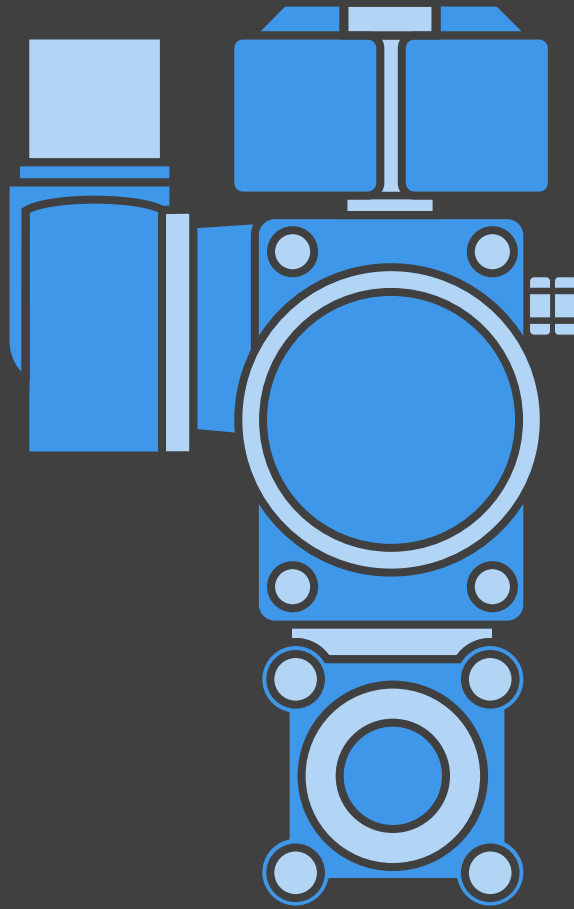

 **REDFLUID**

THE HYDROGEN CHALLENGE



THE HYDROGEN CHALLENGE

Hydrogen infrastructure has many difficulties and at Redfluid we have designed specific range of products in order to solve them all:

We call it the hydrogen challenge:

- Usually High Pressure is required.
- Hydrogen molecule is very small and leaks easily.
- Hydrogen creates hydrides and embrittles the material and damages it.
- It's explosive, colorless & odorless.
- Not compatible with regular materials.



OUR PRODUCTS FOR HYDROGEN ARE CAPABLE TO MEET THE FOLLOWING STANDARDS:

- Clean Fire Safe to maintain hydrogen purity.
- Zero Fugitive Emission
- ATEX Antistatic Certified
- CE / PED
- SIL 2
- ISO 19880-3 Valves for hydrogen fuel stations
- Temperature range -40°C to +120°C
- Materials certificates per EN10204 type 2.2/3.1/3.2
- Certified ISO 9001:2015 in-house high pressure hydrogen laboratory
- 100% leak tested and many on-demand test can be done in our facilities.
- ISO 5211 for actuation
- Special hydrogen grease and sealings
- Hydrogen cleaning and degrease
- Ask for any of those features in your valve or fitting

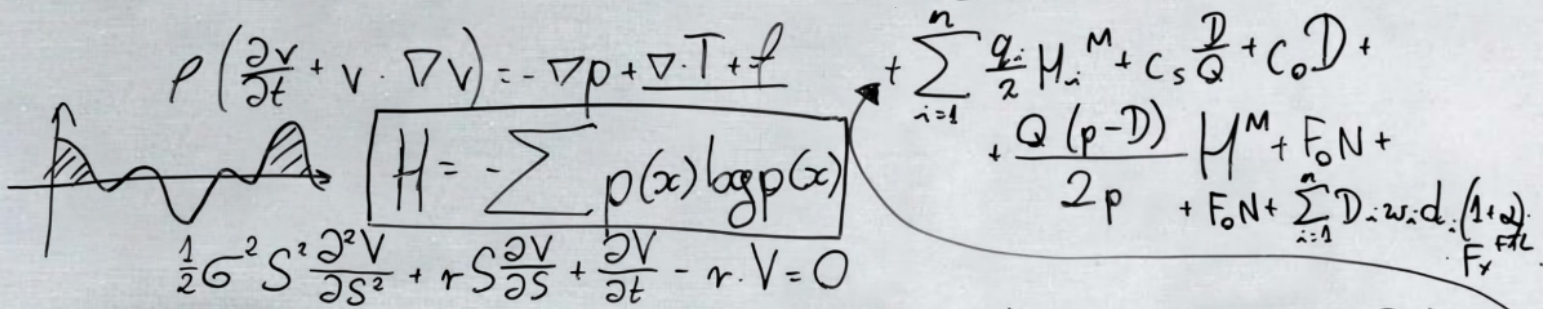

REDFLUID HAS IT'S OWN IN-HOUSE CERTIFIED LABORATORY FOR TESTING VALVES, PRESSURE EQUIPMENT AND METALS.

LABORATORY WITH QUALITY SYSTEM CERTIFIED BY DNV ISO 9001

01



High pressure hydrogen and other gas pressure tests up to 1300 bar

06



Patented Test Bench capable of doing cycles test to check endurance

02



Climatic Chamber to test from -45°C to +300°C

07



Metal optical emission spectrometry (OES) analyzer to perform Positive Material Identification Tests

03



H2 Leak detectors

08



Hydraulic test up to 4000 bar

04



Helium Leak detector detectable leakage rate : 1 x 10⁻¹³ Pa m³/s

09



Vacuum chamber for fugitive emission tests

05









Compressed pure gas 99.999 H2 purity

10

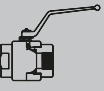

Clean room for degrease and cleaning materials for hydrogen service

INDEX OF HYDROGEN-COMPATIBLE PRODUCTS





	NEEDLE VALVES		AUTOMATION
	CHECK VALVES		FITTINGS
	BALL VALVES		TUBE

In the world of high-pressure hydrogen systems, choosing the right fittings and connectors is crucial. At Redfluid, we offer a comprehensive range of fittings, including needle, check, and ball valves, tailored specifically for various types of hydrogen pipelines. Each family of fittings is designed to seamlessly integrate with a specific type of tubing, ensuring optimal performance and safety. Moreover, our fittings are engineered to withstand varying levels of working pressure, providing the reliability needed for diverse hydrogen applications.

En el mundo de los sistemas de hidrógeno a alta presión, la elección de los racores y conectores adecuados es fundamental. En Redfluid, ofrecemos una amplia gama de racores, incluyendo válvulas de aguja, de retención y de bola, diseñadas específicamente para diversos tipos de tuberías de hidrógeno. Cada familia de racores está concebida para integrarse sin problemas con un tipo particular de tubería, asegurando un rendimiento óptimo y seguridad. Además, nuestros racores están diseñados para soportar diferentes niveles de presión de trabajo, proporcionando la fiabilidad necesaria para diversas aplicaciones de hidrógeno.

En el món dels sistemes d'hidrogen a alta pressió, la tria dels racords i connectors adequats és fonamental. A Redfluid, oferim una àmplia gamma de racords, incloent vàlvules d'aguja, de retenció i de bola, dissenyades específicament per a diversos tipus de canonades d'hidrogen. Cada família de racords està concebuda per integrar-se sense problemes amb un tipus particular de canonada, assegurant un rendiment òptim i seguretat. A més, els nostres racords estan dissenyats per suportar diferents nivells de pressió de treball, proporcionant la fiabilitat necessària per a diverses aplicacions d'hidrogen.

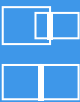
FITTINGS & PRESSURE RECOMMENDATIONS

	HYDROGEN CONNECTION	USUAL PRESSURE RANGE
	THREADED NPT OR BSP	MAXIMUM 600 BAR
	TWIN FERRULE FITTINGS	USUALLY MAXIMUM 400 BAR
	SOCKET WELD OR BUTT WELD	UP TO PRESSURES CORRESPONDING OF SCH 160 OR XXS
	CONE & THREAD	AROUND 1035 BAR AND MORE

HIDRÓGENO / HYDROGEN / HIDROGEN

VÁLVULAS DE AGUJA / NEEDLE VALVES / VÁLVULES D'AGULLA

NEEDLE VALVES



Needle regulating valves suitable for instrumentation circuits and generally high pressure lines up to 4" diameter.

Connexions: Different connections, NPT, BSP, SW, BW, SW OD, Flanged, Mixed, cone & thread.

Materials: Hydrogen ready materials: 316/L as standard and Nitronic 50 as optional. Gaskets, Orings and Packing tested for hydrogen service.

Rating: Different series are available depending on the pressure. The 3000 Series is up to 255 bar, and 6000 Series up to 425 bar. We also have 1035 bar with cone & thread connection.

Temperature: Temperature range acc. ISO 19880-3 is specified as -40 °C / +85 °C

Hydrogen Service: Materials compatible with ISO/TR 15916-2015 Basic considerations for the safety of hydrogen systems. CE EC PED 2014/68/EU certified. ATEX 2014/34/EU certified. ISO 19880-3:2018-3 Gaseous hydrogen Design.

S3000# PRESSURE UP TO PN 250 BAR

STRAIGHT VERSION

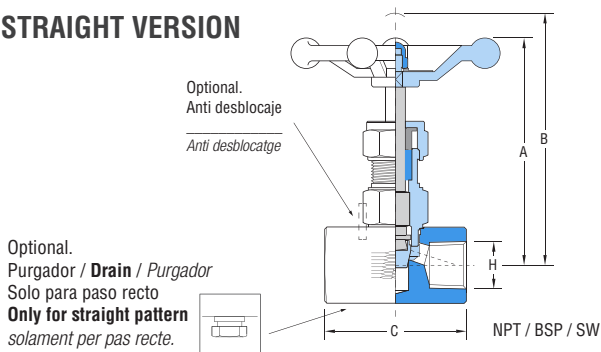

ANGLE VERSION

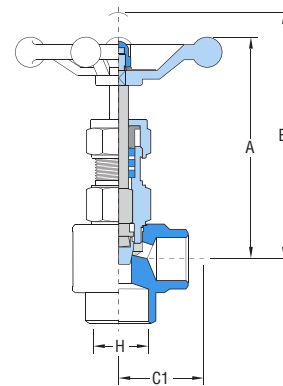

Other Connections

Butt Welding

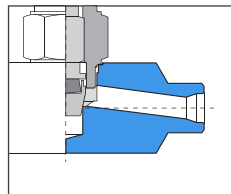

BW	C (mm)
1/4	50
3/8	75
1/2	90
3/4	90
1	100
1 1/4	150
1 1/2	150
2	150
2 1/2	150
3	150
4	175

Socket Welding OD

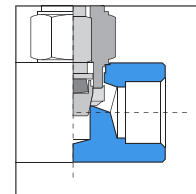

SW	OD
6 mm	1/8"
8 mm	1/4"
10 mm	3/8"
12 mm	1/2"

STRAIGHT VERSION

Connexion (H)	Orifice (mm)	Kv (m³/h)	Weight	A	B	C	C ₁	Reference NPT	Reference BSP	Reference SW
1/4	7	0,7	380 gr	81	88	50	-	3000.02.NP	3000.02.BP	3000.02.SW
3/8	9	1,4	480 gr	84	91	55	-	3000.03.NP	3000.03.BP	3000.03.SW
1/2	12	2,3	750 gr	97	106	65	-	3000.04.NP	3000.04.BP	3000.04.SW
3/4	12	2,9	1 Kg	115	125	75	-	3000.05.NP	3000.05.BP	3000.05.SW
1	16	4,5	1,5 Kg	130	141	90	-	3000.06.NP	3000.06.BP	3000.06.SW
1 1/4	16	4,8	2 Kg	140	155	100	-	3000.07.NP	3000.07.BP	3000.07.SW
1 1/2	21	6	6,5 kg	185	205	125	-	3000.08.NP	3000.08.BP	3000.08.SW
2	21	6,8	6,8 Kg	185	205	125	-	3000.09.NP	3000.09.BP	3000.09.SW
2 1/2	30	9,8		235	250	165	-	3000.10.NP	3000.10.BP	3000.10.SW
3	30	9,8		240	255	165	-	3000.11.NP	3000.11.BP	3000.11.SW
4	30	9,8		255	270	175	-	3000.12.NP	3000.12.BP	3000.12.SW

S6000# PRESSURE UP TO PN 400 BAR

STRAIGHT VERSION

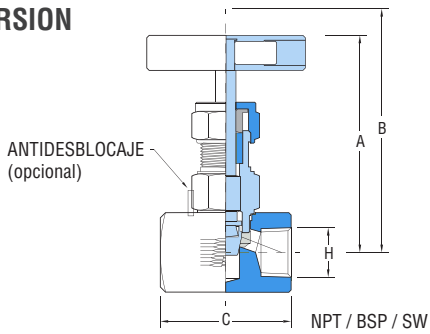

ANGLE VERSION

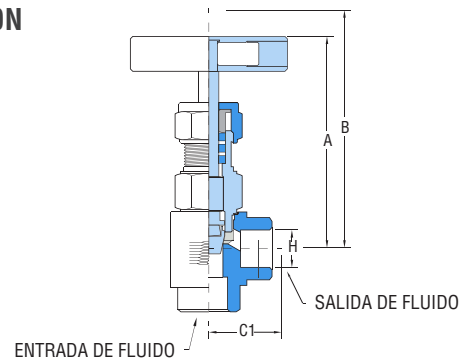

Other Connections Butt Welding Socket Welding OD

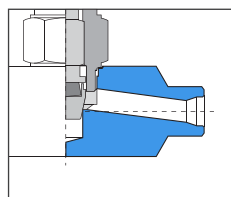

BW	C (mm)
1/4	50
3/8	75
1/2	90
3/4	90
1	100
1 1/4	150
1 1/2	150
2	150
2 1/2	150
3	150
4	175

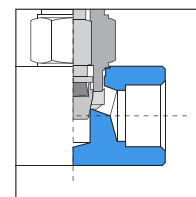

SW	OD
6 mm	1/8"
8 mm	1/4"
10 mm	3/8"
12 mm	1/2"

STRAIGHT VERSION

Connexion (H)	Orifice (mm)	Kv (m³/h)	Weight	A	B	C	C ₁	Reference NPT	Reference BSP	Reference SW
1/4	7	0,7	380 gr	81	88	50	-	3000.02.NP	3000.02.BP	3000.02.SW
3/8	9	1,4	480 gr	84	91	55	-	3000.03.NP	3000.03.BP	3000.03.SW
1/2	12	2,3	750 gr	97	106	65	-	3000.04.NP	3000.04.BP	3000.04.SW
3/4	12	2,9	1 Kg	115	125	75	-	3000.05.NP	3000.05.BP	3000.05.SW
1	16	4,5	1,5 Kg	130	141	90	-	3000.06.NP	3000.06.BP	3000.06.SW
1 1/4	16	4,8	2 Kg	140	155	100	-	3000.07.NP	3000.07.BP	3000.07.SW
1 1/2	21	6	6,5 kg	185	205	125	-	3000.08.NP	3000.08.BP	3000.08.SW
2	21	6,8	6,8 Kg	185	205	125	-	3000.09.NP	3000.09.BP	3000.09.SW
2 1/2	30	9,8		235	250	165	-	3000.10.NP	3000.10.BP	3000.10.SW
3	30	9,8		240	255	165	-	3000.11.NP	3000.11.BP	3000.11.SW
4	30	9,8		255	270	175	-	3000.12.NP	3000.12.BP	3000.12.SW

NEEDLE VALVES VERY HIGH PRESSURE 1035 bar

THREAD TYPES	High-Pressure, Medium-Pressure and NPT
VALVE TYPES	2-Way Straight Valves 2-Way Angle Valves 3-Way Valves (Two inlets under pressure / one inlets under pressures). 3-Way/2-Stem Valves Valves with replaceable seat
MATERIAL	Body: 316 Stainless Steel Stem: Nitroni 150 Sealing: Glas filled Teflon
MAX WORKING PRESSURE	4.140 bar // 60.000 psi
TEMPERATURE	NPT: 18°C to +204°C - HP/MP: -17°C to +315°C

REDFLUID High Pressure hydrogen needle valves are made to the highest quality standards and thus achieve high safety and a long service life even when used in difficult operating conditions. The valves can be used with both gaseous and liquid media and can be opened and/or closed in 4 ½ turns. REDFLUID needle valves allow flow in all directions.

Their innovative design reduces vibrations, which eliminates the necessity of an external clamp to fasten the stem. The valves are also provided with relief holes. The marking on the valves allows them to be traced at any time.

In addition, the REDFLUID needle valves are supplied including collar + gland nut with cone and thread specially designed for hydrogen service.

Nitronic 50 is the material specially selected for the needle to provide high strength and avoid hydrogen embrittlement.



HIDRÓGENO / HYDROGEN / HIDROGEN

VÁLVULAS DE AGUJA / NEEDLE VALVES / VÁLVULES D'AGULLA

NPT & BSP VERSION 1035 BAR

Thread Description	Tube Thread	Screw-in Thread	Orifice	
			mm	inch
Working pressure 1.035 bar / 15.000 psi				
NF4	NPT	1/4"	6,400	0,252
NF6	NPT	3/8"	7,900	0,311
NF8	NPT	1/2"	7,900	0,311

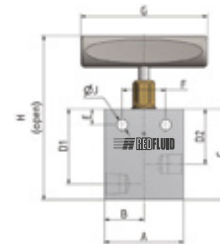

Unit	Dimensions												
	A	B	C	D1	D2	E	F	G	H	I	J	K	L
mm	50,80	25,40	50,80	41,28	30,20	9,70	31,50	76,20	123,00	-	6,40	-	25,40
mm	63,50	31,80	73,20	60,40	44,50	12,70	35,00	102,00	139,00	-	8,70	-	25,40
mm	63,50	31,80	76,20	60,40	44,50	12,70	35,00	102,00	142,00	-	8,70	-	31,60

CONE & THREAD MP 1035 BAR

Thread Description	Tube Thread	Screw-in Thread	Orifice	
			mm	inch
Working pressure 1.380 bar / 20.000 psi				
MF4	1/4"x28UNF LH	7/16"-20UNF	3,175	0,125
MF6	3/8"x24UNF LH	9/16"x18UNF	5,080	0,200
MF9	9/16"x18UNF LH	13/16"-16UNF	7,925	0,312V
MF12	3/4"x16UNF LH	3/4"x14UNF	11,125	0,438
MF16	1"x14UNF LH	1-3/8"x12UNF	14,275	0,562

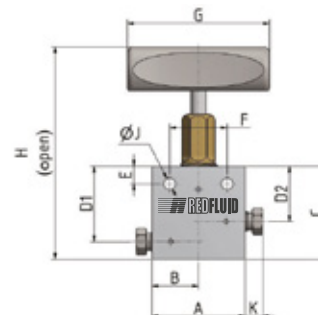

Unit	Dimensions												
	A	B	C	D1	D2	E	F	G	H	I	J	K	L
mm	50,80	25,40	50,80	41,40	30,23	9,65	31,50	76,20	122,94	-	6,35	9,65	25,40
mm	50,80	25,40	50,80	41,40	30,23	9,65	31,50	76,20	122,94	-	6,35	12,19	25,40
mm	63,50	31,75	73,15	60,45	44,45	12,70	35,05	102,00	138,68	-	8,67	17,27	25,40
mm	76,20	38,10	95,25	76,20	57,15	15,75	44,45	204,98	179,58	-	11,18	14,99	35,05
mm	104,65	52,32	120,65	95,25	71,63	28,45	63,50	261,37	227,58	-	14,22	18,80	44,45

SPECIAL DESIGN IN-LINE ALIGNED NEEDLE VALVE 1035 BAR:

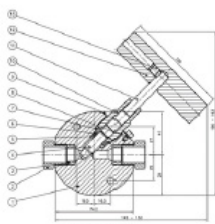

Needle valve with "cone & thread connection and in-line flow.

PN 1035 bar, Material: 1.4404 / AISI316L and Temperature: Max. 230° C

The main advantage is the in-line installation, that make's easier to install the valve in a line without keep changing the different alignments.

There is less resistance in the valve with longer life and avoiding the clog of the valve.

SERIE MINOR / MINOR SERIE / SERIE MINOR

VÁLVULAS DE AGUJA / NEEDLE VALVES / VÀLVULES D'AGULLA



Temperature °C (°F)	Serie AC AC. Al carbono	Serie ss Acero inox	LATÓN
	BAR (PSI)		
-29 to 38 (-20 to 100)	255 (3700)	248 (3598)	153(2220)
200 (392)	-	-	132(1915)
250 (482)	209 (3032)	167 (2423)	-

VALVULAS SERIE MINOR

Especialmente diseñadas para montaje en panel poseen paso reducido, dando una salida de caudal sin pulsaciones y permitiendo una regulación de precisión. Por su fiabilidad son idóneas para utilizar en líneas de mando y paneles de control. Bajo pedido pueden suministrarse con eje especial para alta regulación.

CONEXIONES

Se fabrican en dimensiones desde 1/8" a 1/2" y en versión angular y recta. Las conexiones pueden ser macho, hembra, racores para tubing o mixtas. Roscas estándares según las siguiente normativa:

- NPT ASME B1.20.1
- BSP, gas paralelo DIN 259, ISO 228/1
- BSPT, gas cónico, DIN 2999, EN 102626-1
- Racor de compresión de doble anillo

MATERIALES

Las válvulas de la serie MINOR se fabrican en inoxidable:

- Serie SS. Acero inoxidable tipo 316/316L o 316Ti.

En todos los casos el eje es de acero inoxidable tipo 316. Estopada en anillos de teflón. Bajo pedido pueden suministrarse en otros materiales. Bajo pedido se pueden entregar protocolos de pruebas, así como efectuar cualquier test o requerimiento de cualquier sociedad de clasificación.

MINOR SERIE

Needle valves designed for panel mounting. The valve design permits a precision regulation of the flow and obtains an outlet flow without pulsations. Because of their high performance they are suitable for control panel.

CONNEXIONS

Dimensions from 1/8" to 1/2" in straight and angle pattern. The connectors can be male, female, double ferrule compression fitting for tubing or mixt. Standard threads and connections as per the following standards:

- NPT ASME B1.20.1
- BSP, gas parallel DIN 259, ISO 228/1
- BSPT, gas taper thread, DIN 2999, EN 102626-1
- Twin ferrule compression fitting

MATERIALS

The MINOR series valves are manufactured in stainless steel:

- Series SS. Stainless steel 316/316L o 316Ti.

The needle is in Stainless Steel 316. Packing with Teflon rings. Under request we can supply the valves in any other material.

Ask us for any test protocol, or classification society approvals.

VÀLVULES SERIE MINOR

Especialment dissenyades per a muntatge en panell posseeixen pas reduït, donant una sortida de cabal sense pulsacions. Per la seva fiabilitat són idònies per utilitzar en línies de comandament on sigui necessària una regulació de precisió. Sota comanda poden fabricar-se amb eix especial per a alta regulació.

CONNEXIONS

Es fabriquen en dimensions des de 1/8" a 1/2" i en versió angular i recte. Les connexions poder ser mascle, femella, ràcords per tubing o mixtes. Rosques estàndards segons la següent normativa:

- NPT ASME B1.20.1
- BSP, gas paral·lel DIN 259, ISO 228/1
- BSPT, gas cònic, DIN 2999, EN 102626-1
- Ràcord de compresió de doble anell

MATERIALS

Las vàlvules de la sèrie MINOR es fabriquen en inoxidable:

- Sèrie SS. Acero inoxidable tipus 316/316L o 316Ti.

En tots els casos el eix es de acer inoxidable tipus 316. Estopada en anelles de tefló. Sota comanda es pot subministrar amb altres materials. Per fer la comanda nomes cal indicar la referencia concreta de cada vàlvula i afegir el codi del material desitjat.

Para pedido basta con indicar la referencia concreta de cada válvula y añadir el código del material deseado.

To make an order specify the valve reference and the code of the material.

Per fer la comanda nomes cal indicar la referencia concreta de cada vàlvula i afegir el codi del material desitjat.

REFERENCE
Serie Normal
Serie "C" Reforzada

MATERIAL
SS: acero inoxidable

SERIE MINOR / MINOR SERIE/ SERIE MINOR
VÁLVULAS DE AGUJA / NEEDLE VALVES / VÀLVULES D'AGULLA

MALE - FEMALE

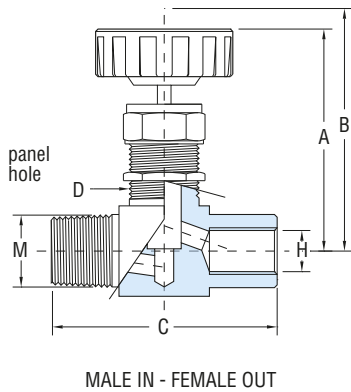

**MALE- FEMALE
ANGLE VERSION**

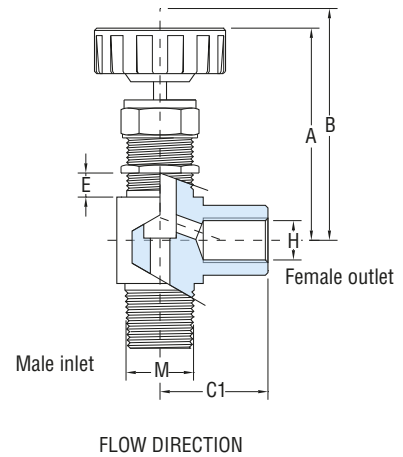

MALE - FEMALE

Connexion (H)	Orifice (mm)	A	B	C	C ₁	D	E	Reference NPT	Reference BSPT x BSP
1/8	4,5	70	77	51	-	20,5	6	565.01.NP	565.01.GS
1/4	4,5	70	77	56	-	20,5	6	565.02.NP	565.02.GS
3/8	6,5	70	77	57	-	20,5	6	565.03.NP	565.03.GS
1/2	8	90	100	68	-	24,5	8	565.04.NP	565.04.GS

MALE - FEMALE ANGLE VERSION

1/8	4,5	70	77	-	26	20,5	6	566.01.NP	566.01.GS
1/4	4,5	70	77	-	26	20,5	6	566.02.NP	566.02.GS
3/8	6,5	70	77	-	26	20,5	6	566.03.NP	566.03.GS
1/2	8	90	100	-	30	24,5	8	566.04.NP	566.04.GS

**COMPRESSION
FITTING
STRAIGHT VERSION**

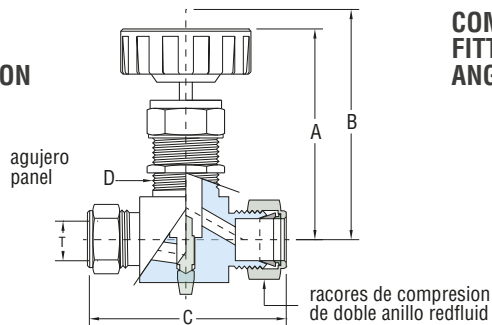

**COMPRESSION
FITTINGS
ANGLE VERSION**

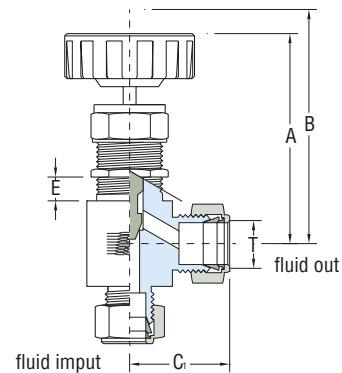

STRAIGHT VERSION

Connexion (H)	Orifice (mm)	A	B	C	C ₁	D	E	Reference NPT	Reference BSPT x BSP
1/8	4,5	70	77	55	-	20,5	6	550.1/4.1/4	550.06.06
1/4	4,5	70	77	55	-	20,5	6	550.5/16.5/16	550.08.08
3/8	6,5	70	77	65	-	20,5	6	550.3/8.3/8	550.10.10
1/2	8	90	100	75	-	24,5	8	550.1/2.1/2	550.12.12

ANGLE VERSION

11/4	4,5	70	77	-	27	20,5	6	551.1/4.1/4	551.06.06
5/16	4,5	70	77	-	27	20,5	6	551.5/16.5/16	551.08.08
3/8	4,5	70	77	-	32	20,5	6	551.3/8.3/8	551.10.10
1/2	6,5	90	100	-	36	20,5	8	551.1/2.1/2	551.12.12

SERIE MINOR SERIE "C" - REINFORCED DESIGN 6500psi 450 bar

NEEDLE VALVES / VALVULAS DE AGUJA / VÀLVULES D'AGULLA

- Pressure up to 6,500 psig(450 bar).
- Standard PTFE Material Temperature Range: -40°C to +110°C.
- High Temperatures up to -54°C to 230°C on request
- Standard in 316 stainless steel
- Valve stem back seating against the bevelled edge of bonnet in fully open position prevents maximum leakage through bonnet when packing fails.
- Standard non-rotating needle and stem packing below the threads design.
- ATEX 2014/34/EU Design.
- CE EC PED 2014/68/EU

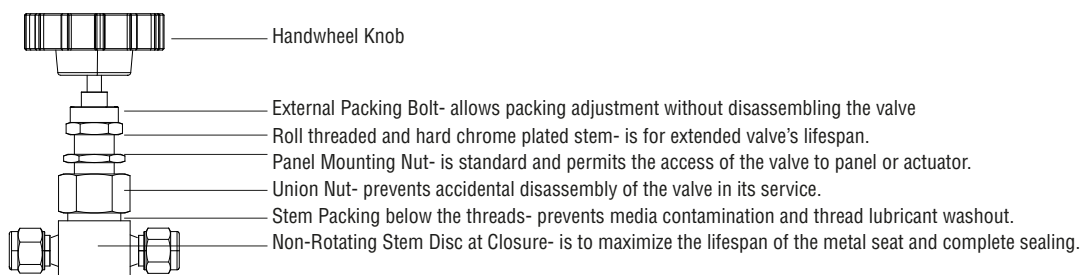

Component	Valve Body Materials
1. Handwheel	Baquelite Knob
2. Set screw	Grade B8 TYPE 304/A19
3. Packing bol	S316/A276 or A479
4. Cap nut	S316/A276 or A479
5. Bonnet *	S316/A276 or A479
6. Gland	S316/A276 or A47
7. Packing *	PTFE/D1710, optional PEEK & Graphite
8. Packing supports	Reinforced PTFE
9. Stem	Hard Chrome-plated S316/A276 or A479
10. Needle	TYPE630 A564 (17-4PH)
11. Panel nut	S316/A276 or A479
12. Union nut	S316/A276 or A479
13. Body	S316/A276 or A47

COMPRESSION FITTINGS ANGLE VERSION

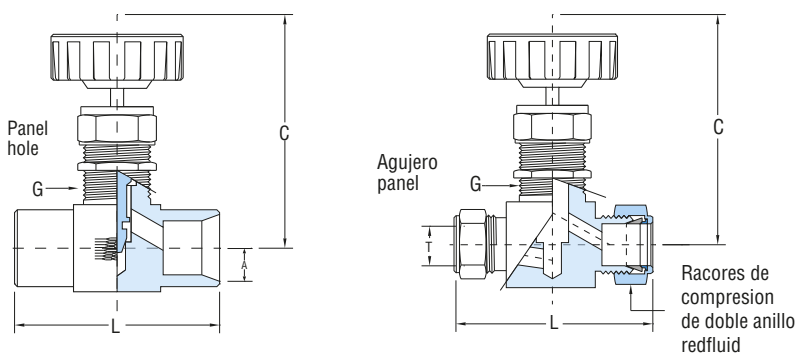

Connection	Diameter Orifice mm	CV	L	A	G	C
1/8" F NPT	4	0,35	50	10	15	77,2
1/4" F NPT			52			
1/4" M NPT			50			
1/4" MF NPT			51			
6 mm OD Twin Ferrule	6,4	0,86	61	12,5	20	94
1/4" OD Twin Ferrule			61			
8 mm OD Twin Ferrule			61			
3/8" F NPT			57			
10 mm OD Twin Ferrule	11,1	2,2	72	15,7	26	120
3/8" OD Twin Ferrule			72			
12 mm OD Twin Ferrule			77			
1/2" OD Twin Ferrule			77			
1/2" F NPT	11,1	2,2	79	19,8	26	125
3/4" F NPT			82			
1" F NPT			92			
1" F NPT	11,1	2,2	92	25,4	26	130

SERIE MINOR SERIE "9500" | PN 650 bar

NEEDLE VALVES / VALVULAS DE AGUJA / VÀLVULES D'AGULLA

- Pressure up to 9,500 psig (650 bar).
- Standard PEEK + RPTFE Packing Material Temperature Range: -40°C to +110°C.
- High Temperatures up to -54°C to 230°C on request
- Standard in 316 stainless steel NACE
- Valve construct and end thickness meet ANSI B16.34
- End Cap Possibilities: NPT, BSP, SW, BW, Twin Ferrules
- Hydrogen Service with very low Fugitive Emission
- Panel Mounting Nut
- ATEX 2014/34/EU Design.
- CE EC PED 2014/68/EU

Included Tests:
 100% Pneumatic Test 6 bar (air)
 100% Pneumatic Test Hydrogen PNx1.5
 100% Hydrostatic Test 1.5 x PN (water/oil)

LEAKAGE CLASS EN 12266-1: 0 bubble 2 min.
 ZERO LEAKAGE ISO 5208 | API 598 Rate A
 EN 10204 3.1 Certificate

Optional Tests:
 FAT 100% Hydrogen Pure 99,999 Tested at PNx1,1
 Positive Material Identification Test, Cycle Test, Vacuum Test
 Tests carried out at Redfluid ISO 9001 Hydrogen Laboratory

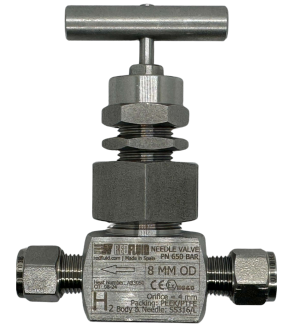
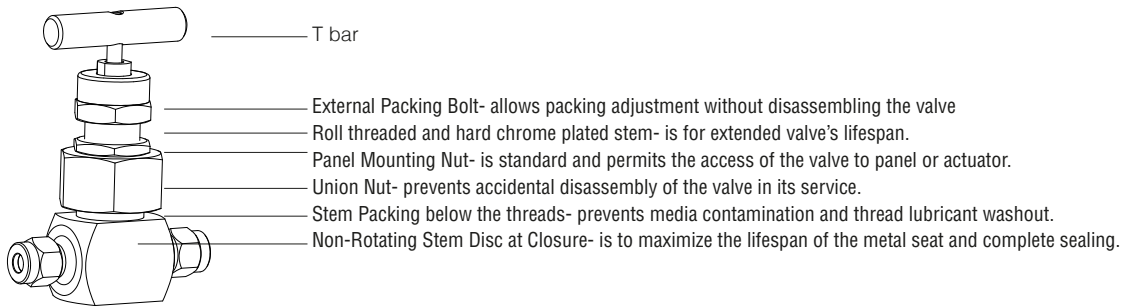

Component	Valve Body Materials
1. T Bar Handle	SS316/L
2. Panel Nut Metric	SS316/L
3. Lock Nut	SS316/L
4. Union Nut	SS316/L
5. Packing Bolt	SS316/L
6. Gland	SS316/L
7. First Packing Ring	RPTFE
8. Second Packing	PEEK
9. Bonnet	SS316/L
10. Needle	SS316/L
11. Valve Body	SS316/L
12. Ferrules	SS316/L
13. Nut	SS316/L

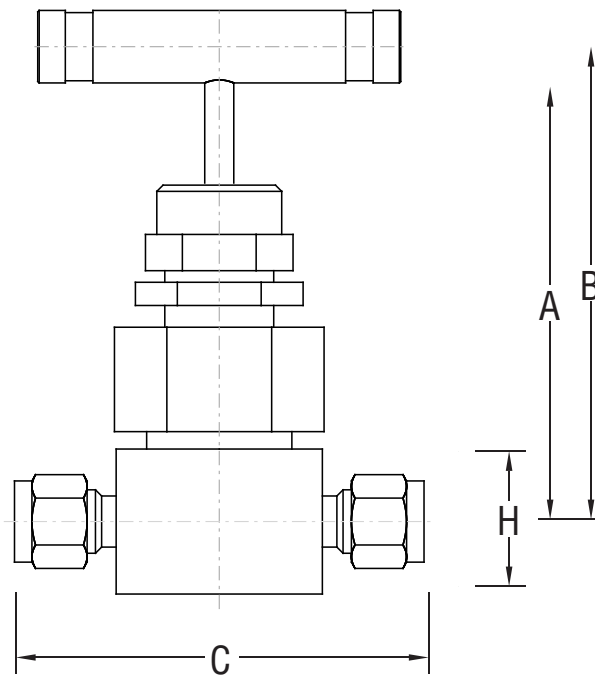

H2 HP S-MINOR S9500# Orifice: 4mm Cv=0.35 USgalon/min

Connexion (H)	Orifice (mm)	A	B	C	C ₁	PN	Reference NPT / OD
6 MM OD	4,0	87	97	71	-	650 bar	550.HP.H2.006
8 MM OD	4,0	87	97	71	-	650 bar	550.HP.H2.008
1/4" H NPT	4,0	87	97	57	-	650 bar	550.HP.H2.RN.140

Optional Configuration:
 (Minimum Order Qty required)

- Needle in Nitronic 50 or Alloy 718
- Packing in Vespel

CHECK VALVES

PN 250 CHECK VALVE

Description	AC Serie	SS Serie
Tapón válvula/Cap	Carbon Steel	SS 316 / 316L
Resorte / Spring	SS 316 / 316L	SS 316 / 316L
Pistón / Poppet	SS 316 / 316L	SS 316 / 316L
Junta / Oring	FKM	FKM
Cuerpo / Body	Carbon Steel	SS 316 / 316L



CIERRES / CLOSING / TANCAMENTS

Mod. 1

VERSION CON RESORTE DE COMPENSACIÓN.
SPRING VERSION
VERSIO AMB RESSORT DE COMPENSACIÓ

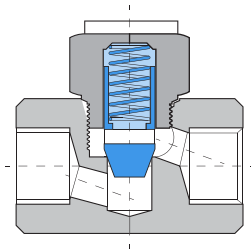

Mod. 2

VERSION CON PISTÓN LIBRE
SPRING FREE VERSION
VERSIO AMB PISTÓ LLIURE

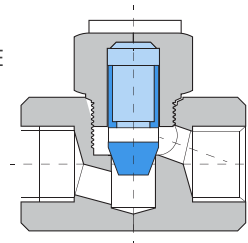

Presión de apertura standard=0,5 bar
Podemos entregar la válvula para que abra la presión deseada.

Standard cracking pressure=0,5 bar.
Ask us for any other cracking pressure.

Pressió d'obertura estàndard = 0,5 bar
Podem lliurar la vàlvula per que obri la pressió desitjada.

SERIE MEDIA / MEDIUM SERIE / SÈRIE MEDIA

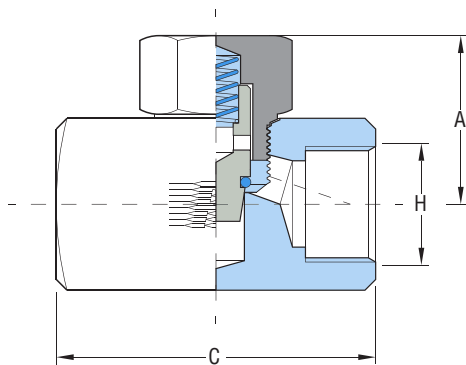

H	L	A	Orifice (mm)	Reference Mod. 2 NPT	Reference Mod. 2 BSP
1/8	50	30	7	3250.01.NP	3250.01.BP
1/4	50	30	7	3250.02.NP	3250.02.BP
3/8	55	32	9	3250.03.NP	3250.03.BP
1/2	65	38	12	3250.04.NP	3250.04.BP
3/4	85	42	14	3250.05.NP	3250.05.BP
1	90	53	17	3250.06.NP	3250.06.BP
1 1/4	100	55	17	3250.07.NP	3250.07.BP
1 1/2	125	68	21	3250.08.NP	3250.08.BP
2	125	68	21	3250.09.NP	3250.09.BP

Bajo pedido se pueden entregar protocolos de pruebas, así como efectuar cualquier test o requerimiento de cualquier sociedad de clasificación.

Sota demanda es poden entregar protocols de proves, així com efectuar qualsevol test o requeriment de qualsevol societat de classificació.

Temperature °C (°F)	Carbon Steel	Stainless Steel	Brass
	BAR (PSI)		
-29 to 38 (-20 to 100)	255 (3700)	248 (3600)	153 (2220)
200 (392)	-	-	132 (1915)
400 (752)	172 (2495)	145 (2104)	-

BALL VALVES / 3 PIECES DESIGN UP TO 64 BAR

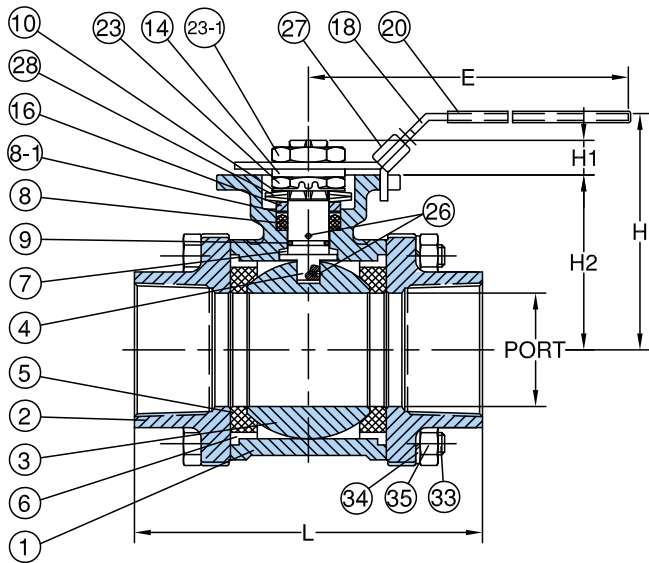

- Materials according ISO/TR 15916-2015 Considerations for the safety of H2 systems
- 3-piece Ball valve CF8M 1.4408 - 1000 psi
- Body & End Cap are investment cast
- Ball in 1.4401 316
- Seats in FTM 1600
- NACE MR 0175 Compliance
- Steam Sealing material: RPTFE
- Special Hydrogen FKM Oring Norosl H2 FKM90 Anti Explosive Decompression AED
- Self adjusting stem packing
- Blow-Out proof stem design
- 100% Air Tested
- ISO 5211 Direct mounting Pad for actuator
- End Cap Possibilities: NPT, BSP, SW, BW
- Valve construct and end thickness meet ANSI B16.34
- Fugitive Emission ISO 15848-1:2015 CO3 - 2500 CYCLES BH RT
- ATEX 2014/34/EU
- SIL 2 IEC 61508 Capable
- CE EC PED 2014/68/EU
- Anti-Static Design
- Full bore
- Temperature Rating: -40°C to +200°C
- Mounting Pad ISO 5211
- Locking Device
- Laser Marking
- Individual packing in Plastic Bag for Oxygen Service ASTM G127-15 & Protecting Cap
- Leak rate: A as per EN 12266-1 (0 bubble)
- EN 10204 3.1 Certificate

No	Name of parts	Materials
1	Body	ASTM A351 CF8M
2	End cap	ASTM A351 CF8M
3	Ball	ASTM A351 CF8M
4	Stem	ASTM A276 Gr.316
5	Seat	TFM 1600
6	Body Seal	PTFE
7	Thrust Washer	PTFE
8	Stem Packing	PTFE
8-1	Packing Follower	PTFE +25% G.F.
9	Stem O-Ring	FKM 90 AED NOROSK
10	Stop Ring	ASTM A276 Gr.304
14	Gland	ASTM A276 Gr.304
16	Packing Gland	ASTM A276 Gr.304
18	Handle	ASTM A276 Gr.304
20	Handle Cover	PLASTIC
23	Stem Nut	ASTM A276 Gr.304
23-1	Handle Nut	ASTM A276 Gr.304
26	Anti-Static Device	ASTM A276 Gr.316
27	Handle Lock	ASTM A276 Gr.304
28	Belleville Washer	ASTM A276 Gr.301
31	Stop Pin	ASTM A276 Gr.304
33	Body Bolt	ASTM A276 Gr.304
34	Bolt Washer	ASTM A276 Gr.304
35	Body Nut	ASTM A276 Gr.304

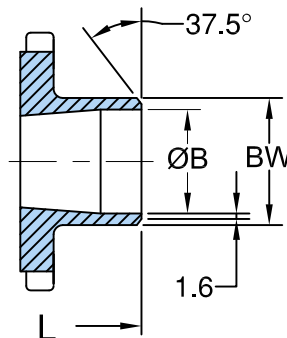

Butt Weld End

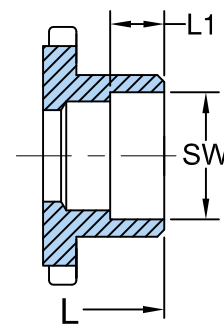

Socket Weld End

Ends: BSPP (ISO 228) - NPT (ASME B1.20.1) -SAE J1926-1, SW (ANSI B16.11), BW EN12627

Dimensions

Size	PORT	L	L1	E	H	H1	H2	C	ØK	ØK1	Z	Z1	SW	ØB	BW	Tn	Wg	
DN8	1/4"	11.5	63.5	10.0	112.0	73.0	8.5	37.0	9.0	50.0	36.0	7.0	6.0	14.2	9.2	13.7	-	0.5
DN10	3/8"	12.5	63.5	10.0	112.0	73.0	8.5	37.0	9.0	50.0	36.0	7.0	6.0	17.6	12.5	17.1	-	0.5
DN15	1/2"	15.0	63.5	10.0	112.0	73.0	8.5	37.0	9.0	50.0	36.0	7.0	6.0	21.8	15.7	21.3	-	0.5
DN20	3/4"	20.0	72.5	13.0	112.0	80.8	8.5	45.0	9.0	50.0	36.0	7.0	6.0	27.2	21.0	26.7	-	0.7
DN25	1"	25.0	81.0	13.0	136.0	90.5	9.5	53.5	9.0	50.0	36.0	7.0	6.0	33.9	26.6	33.4	-	1.0
DN32	1-1/4"	32.0	94.5	13.0	185.0	98.7	9.5	59.0	9.0	50.0	36.0	7.0	6.0	42.7	35.0	42.2	-	1.6
DN40	1-1/2"	40.0	108.0	13.0	197.9	115.3	14.0	74.8	14.0	70.0	50.0	9.0	7.0	48.8	41.0	48.3	-	2.4
DN50	2"	50.0	121.5	16.0	197.9	124.0	13.7	83.5	14.0	70.0	50.0	9.0	7.0	61.2	52.5	60.3	-	3.5
DN65	2-1/2"	65.0	157.5	16.0	267.0	155.0	18.0	108.8	17.0	102.0	70.0	12.0	10.0	73.9	62.7	73.0	-	7.5
DN80	3"	80.0	190.0	16.0	267.0	164.5	18.0	118.3	17.0	102.0	70.0	12.0	10.0	89.8	77.9	88.9	-	11.2
DN100	4"	100.0	225.0	22.0	322.0	216.7	18.0	153.8	17.0	102.0	70.0	12.0	10.0	115.2	102.3	114.3	-	21.8

HIDRÓGENO / HYDROGEN / HIDROGEN

VÁLVULAS DE BOLA / BALL VALVES / VÁLVULES DE BOLA

BALL VALVES / 3 PIECES DESIGN UP TO 250 BAR

A specially designed hydrogen 3 pieces ball valve, compliant with ISO 19880-3, offers key benefits:

- Clean Fire Safe: Engineered for enhanced safety in hydrogen environments.
- Reduced Fugitive Emissions: Minimizes or eliminates leaks, crucial for safety and efficiency.
- Compliance with International Standards: Meets ISO 19880-3 for quality and safety assurance.
- Optimized for High Pressure: Ensures optimal performance in high-pressure applications.
- Durable and Reliable: Built to withstand harsh hydrogen service conditions



TECHNICAL FEATURES

- Materials according ISO/TR 15916-2015 Considerations for the safety of H2 systems
- H2 Service with: Peek Seat/Thrust washer, Graphite Gasket/Stem Packing & FKM AED oring
- NOROSK H2 FKM 90 Oring PLT/ED LT -41°C / +220°C (Very Short time +250°C)
- Clean Fire Safe w/ Double Packing that maintains H2 purity
- Valve construct and end thickness meet ANSI B16.34
- Design pressure as per CF3M 3600psi PN248 CF3M ASME B16.34
- Body & End Cap are investment cast NACE MR 0175
- Self adjusting Belleville stem packing
- Blow-Out proof stem design
- 100% Air Tested under water at 80-100 psi
- Design Pressure 3600 PSig (max) - PN 248 bar
- ISO 5211 Direct Mounting Pad for actuator

End Cap Possibilities: NPT, BSP, SW, BW
 Fire Safe Certificate API607
 Fugitive Emission ISO 15848-:2006
 Locking Device
 ATEX 2014/34/EU
 SIL 2 IEC 61508 PARTS 1-2 AND 4-7:2010
 CE EC PED 2014/68/EU
 Anti-Static Device
 Pressure release Hole & Belleville Washer
 Full bore
 H2 ISO 19880-3 102000 cycles tested
 Technical Features
 Silicone Free Grease°

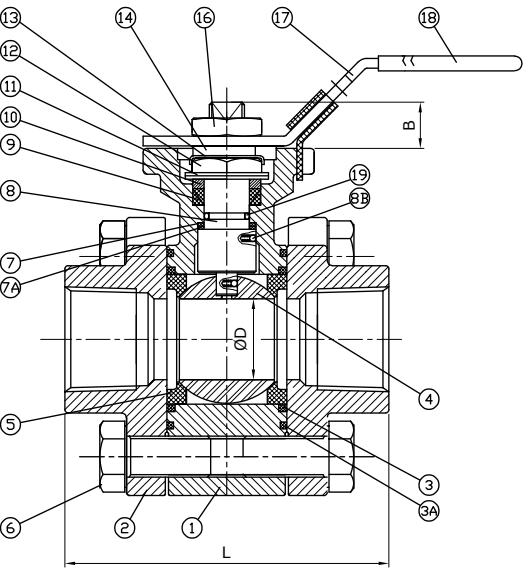

Name of parts	Materials
1- Body	CF3M (316L)
2- End cap	CF3M (316L)
3- Gasket (Body) (A)	PFE
3A- Gasket (Body) (B)	GRAPHITE
4- Ball	CF3M (316L)
5- Ball seats	PEEK
6- Bolts	SS 304
7- Thrust Washer	PEEK
7A- Thrust Washer	PEEK
8- Stem	SS 316 L
8A- Half Split Ring	SS 316 L
8B- Ant-Static	SS 316
9- Stem Packing	GRAPHITE
10- Gland Washer	SS 304
11- Disk Washer	SS 304
12- Stem Nut	SS 304
13- Nut Stop	SS 304
14- Space Washer	SS 304
15- Stop Pin	SS 304
16- Handle Nut	SS 304
17- Handle	SS 304
18- Handle Cover	PLASTISOL
19- O-Ring	KFM AED

OPTIONAL CONFIGURATION: (Minimum order quantity required)

- Twin Ferrule Endings
- Long BW Welded Ends
- BW Eneds B16.25
- Ball and / or Stem in Nitronic 50 or Alloy 718
- Seats in Vespel
- Cleaning & Degrease

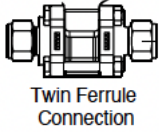
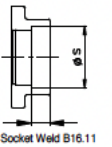
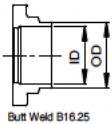

UNIT: mm												
CODE	SIZE	A	B	C	D	D1	D2	d1	d2	H	L	ISO
A10002NPIH2 A10003NPIH2	1/4", 3/8"	46	9.5	160	11	36	42	6.0	7.0	9	66.5	F03/F04
A10004NPIH2	1/2"	48	9.5	160	15	36	42	6.0	7.0	9	70	F03/F04
A10004NPIH2	3/4"	53	12	190	20	-	50	-	7.2	11	92	F05
A10004NPIH2	1"	59	12	190	25	-	50	-	7.2	11	105	F05

Torque N-m			
SIZE	PN64	PN110	PN200
1/4", 3/8"	18	20	25
1/2"	18	20	25
3/4"	26	42	55
1"	37	47	59

BALL VALVES / 2 PIECES DESIGN UP TO 500 BAR

BALL VALVE PN 500 BAR



VÁLVULA DE BOLA 2 VIAS PASO TOTAL INOXIDABLE / SS316/L 2 WAY BALL VALVE / VÁLVULA DE 2 VIES PAS TOTAL 316/316L

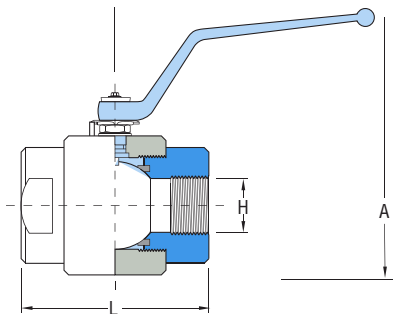

TEMPERATURES MATERIAL	
POM	-30° a + 100°
*NBR	-35° a + 100°
PTFE	-200° a + 230°
PEEK	-50° a + 250°
*VITON/FKM	-25° a + 200°
*EPDM	-50° a + 150°
RPTFE	-220° a + 230°
*FFKM	-30° a + 400°
Metal-Metal	-200°C a +400°

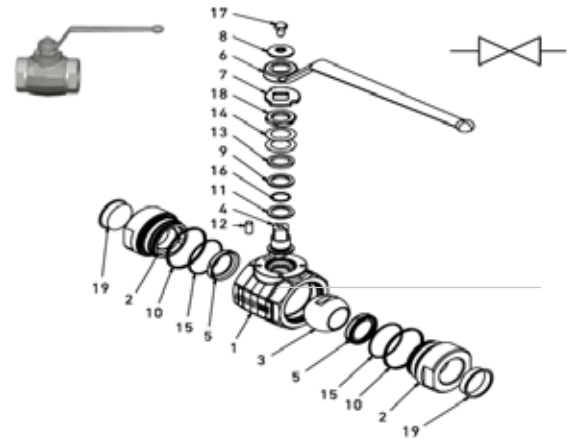

S20 SS316/316L 1.4401/1.4404 NPT - SW - BSP

H	Full B (mm)	A	C1	L	DN	PN (bar)
1/4	6	109	110	72	8	500
3/8	10	109	110	72	10	500
1/2	13	115	110	81	15	500
3/4	20	122	180	98	20	400
1	25	133	180	106	25	350
1 1/4	32	120,5	300	127	32	350
1 1/2	40	134,5	300	135	40	350
2	50	140,5	300	160	50	350
2 1/2	65	226	600	174	65	150
3	80	241	600	191,5	80	100
4	100	278,5	600	230	100	50

CARBON STEEL OR STAINLESS STEEL

- Type: ball valve 2 way
- Material: 1.0570 or 1.4404
- Sizes: from DN6 up to DN100
- Ends: BSPP (ISO 228) - NPT (ASME B1.20.1)-SAE J1926-1, SW (ANSI B16.11) or welded BW nipple ends; DIN 2353 Single Ferrule Fitting; Twin Ferrule Fitting
- O-Rings: Standard: NBR, Optional: FKM, EPDM, MVQ Seats: POM (STANDARD); RPTFE, PEEK OR PA612 Optional
- Pressure: up to PN500
- Temp range: Depending on the seats & materials: -46°C to +250°C
- ATEX CERTIFIED
- CE PED & TRCU EAC
- Fire Safe BS6755 & Antistatic Device
- Fugitive Emission Design
- SIL 2 Capable

STANDARD MATERIAL

Description	Material
1- Cuerpo / Body	AISI 316/316L
2- Adaptador / Adapter	AISI 316/316L
3- Bola / Ball	AISI 316/316L
4- Vástago / Stem	AISI 316/316L
5- Asiento / Ball Seat	Poliacetal (POM)
6- Maneta / Handle	1.0116
7- Arandela / Washer	1.4301
8- Arandela / Washer	1.4301
9- Junta / Body Ring	Graphite
10- Junta / Adapter Ring	Graphite
11- Junta / Stem Ring	PTFE
12- Pin	1.4301
13- Anillo / Press Ring	1.4301
14- Muelle / Spring	1.4301
*15- Junta / Adapter Oring	NBR
*16- Junta/ Stem Oring	NBR
17- Tornillo / Screw	DIN6921 A2
18- Tuerca / Nut	1.4301
19- Tapón/ Cap	PVC

VERY HIGH PRESSURE BALL VALVE / UP TO 1035 BAR

High-pressure hydrogen application undergo meticulous engineering and rigorous testing to ensure the highest standards of safety, performance and durability. Redfluid valves are subjected to extensive testing, surpassing 102,000 operative cycles. They conform Fugitive Emission standard ISO 15848-1 and ISO 19880-3 for refuelling stations. Our valves feature specialized stem seals with low permeability, carefully chosen for hydrogen applications. Additionally, we offer double stem seals, ATEX and UE Pressure Equipment Directive PED. Our valves feature a compact design that reduces costs and system footprint while enhancing operational efficiency. They offer peak efficiency with a full bore design, eliminating pressure drops for faster discharge. Designed to operate in temperatures from -40°C to +140°C and at pressures up to 690 bar, these valves are built to endure demanding conditions.

THREAD TYPES:	High-Pressure, Medium-Pressure and NPT
VALVE TYPES:	2-Way Straight Valves 2-Way Angle Valves 3-Way Valves (Two inlets under pressure / one inlets under pressures). 3-Way/2-Stem Valves Valves with replaceable seat
MATERIAL:	Body: 316 Stainless Steel Stem: Nitroni 150 Sealing: Glas filled Teflon
MAX WORKING PRESSURE	4.140 bar // 60.000 psi
TEMPERATURE	NPT: 18°C to + 204°C - HP/MP: -17°C to +315°C

Materials according ISO/TR 15916-2015 Considerations for the safety of H2 systems
NOROSK H2 FKM 90 Oring PLT/ED LT -40°C / +180°C
Valve construct and end thickness meet ANSI B16.34
NACE MR 0175 material compliance

Blow-Out proof stem design
100% Air Tested under water at 80-100 psi
ISO 5211 Direct Mounting Pad for actuator
End Cap Possibilities: NPT, BSP, SW, BW

Fugitive Emission ISO 15848-2:2006
Locking Device
ATEX 2014/34/EU
SIL 2 IEC 61508 PARTS 1-2 AND 4-7:2010
CE EC PED 2014/68/EU
Anti-Static Device

Full bore / Reduced Bore
H2 ISO 19880-3 102000 cycles tested
Silicone Free Grease

TESTS OPCIONALES:FAT 100% Hydrogen
Pure 99,999 Tested at PN1,1FAT 100%

FugitiveEmission Production Test 5% Hydrogen
or Helium ISO15848-2 <50 ppmv







Las válvulas de bola de ultra alta presión para estaciones de abastecimiento de hidrógeno y aplicaciones de hidrógeno a alta presión se someten a una ingeniería meticulosa y a pruebas rigurosas para garantizar los más altos estándares de seguridad, rendimiento y durabilidad.

Las válvulas Redfluid se someten a pruebas exhaustivas, superando las 102,000 operaciones cíclicas. Cumplen con la norma de Emisiones Fugitivas ISO 15848-1 y con la norma ISO 19880-3 para estaciones de repostaje.

Nuestras válvulas cuentan con sellos de vástago especializados de baja permeabilidad, cuidadosamente seleccionados para aplicaciones de hidrógeno. Además, ofrecemos sellos de doble vástago, certificaciones ATEX y la Directiva de Equipos a Presión de la Unión Europea (PED).

Nuestras válvulas cuentan con un diseño compacto que reduce costos y el espacio necesario del sistema, al tiempo que mejora la eficiencia operativa. Ofrecen una eficiencia óptima con un diseño de paso completo, eliminando las caídas de presión para una descarga más rápida. Diseñadas para operar en temperaturas que van desde -40°C hasta +140°C y a presiones de hasta 690 bar, estas válvulas están construidas para resistir condiciones exigentes.



 HIGH PRESSURE	Conducting pressure tests in accordance with DIN EN 12266-1 and DIN EN 14246 utilizing a test gas composed of nitrogen and helium. Static and cyclic high-pressure With air at pressures up to 550 bar and nitrogen at pressures up to 1000 bar. Temperature range spanning from -40 °C to +85 °C.
 HIGH TEMPERATURE	Materials that are appropriate for use within the temperature range of -40 °C to +140 °C. It is important to note that the specified temperature range according to ISO 19880-3 is -40 °C to +85 °C.
	Valve and material is certified according Pressure Equipment Directive: CE EC PED 2014/68/EU
 CLEAN AND DEGREASED	Producing oil and grease-free products by utilizing ultrasonic cleaning techniques. Assembling valves without the need for any additional lubrication on the surfaces that come into contact with liquids.
 ATEX	ATEX certification, short for "Atmosphères Explosibles," is a crucial safety certification for equipment and systems used in potentially explosive atmospheres.
 LABORATORY WITH QUALITY SYSTEM CERTIFIED BY DNV ISO 9001	ISO 9001 certified

AUTOMATION

BENEFICIOS

Automatización posible utilizando electricidad o aire. Reducción de la necesidad de mano de obra.

El actuador de simple efecto permite la capacidad de controlar de forma remota una válvula. Si el actuador pierde potencia, tiene un muelle interior que se expande y devuelve la válvula a su posición original, conocida como "fail position".

Pinturas y acabados anticorrosión para ambientes extremadamente corrosivos como desalación o buques mercantes.



BENEFITS

Automation possible using electricity or air. Reduced need for labor. Single-acting actuator allows the ability to control a valve remotely. If the actuator loses power, it has an internal spring that expands and returns the valve to its original position, known as the "fail position". Anti-corrosion paints and finishes for highly corrosive environments such as desalination or merchant ships.

TIPOS DE ACTUADORES / TYPES OF ACTUATORS / TIPUS D'ACTUADORS

ACTUADOR ELÉCTRICO

Multivoltaje desde 12v hasta 240 v en corriente continua o alterna. Posibilidad de incorporar un DPS (sistema de posicionamiento digital) y una batería BSR (Sistema de retorno por batería). IP67, -20°C hasta +70°C.

ELECTRIC ACTUATORS

Multi-voltage from 12v to 240v in direct or alternating current. Possibility of incorporating a DPS (Digital Positioning System) and a BSR battery (Battery Return System). IP67, -20°C to + 70°C.

ACTUADOR ELÈCTRIC

Multivoltatge des de 12 fins a 240 veuen corrent continu o alterna. Possibilitat d'incorporar un DPS (sistema de posicionament digital) i una bateria BSR (Sistema de torn per bateria)

ACTUADORES NEUMÁTICOS SIMPLE Y DOBLE EFECTO

Multitud de actuadores neumáticos de aluminio con recubrimiento para ambientes marinos muy corrosivos tipo C5 ISO 12944. Nuestros actuadores pueden ser accionados con aire, agua o fluido no agresivos hasta 8 bar de presión. Temperatura de funcionamiento: -32°C hasta +80°C

SINGLE AND DOUBLE ACTING PNEUMATIC ACTUATORS

A multitude of aluminum pneumatic actuators with coating for highly corrosive marine environments type C5 ISO 12944. Our actuators can work with air, water or nonaggressive fluid up to 8 bar pressure. Operating temperature: -32°C to + 80°C

ACTUADORS PNEUMÀTICS SIMPLE I DOBLE EFECTE

Multitud d'actuadors pneumàtics d'alumini amb recobriment per a ambients marins molt corrosius tipus C5 ISO12944. Els nostres actuadors poden ser accionats amb aire, aigua o fluid no agressius fins a 8 bar de pressió. Temperatura de funcionament: -32°C fins a+80°C



Electroválvula NAMUR / Solenoid valve NAMUR

Material electroválvula: Aluminio recubierto con cromo trivalente.
Placa intermedia: Placa de conversión de 5/2 a 3/2.
Protección: IP-65.
Presión: MIN. 2 bar y MAX. 8 bar.
Función: 5/2 VIAS y 3/2 VIAS.
Tensiones disponibles: 24V AC/DC, 110V AC, 220V AC
Opciones: Namur, no Namur, Eexi y Eexd.

Solenoid valve material: Aluminium coated with trivalent chromium.
Intermediate plate: Conversion plate of 5/2 to 3/2.
Protection: IP-65.
Pressure: MIN. 2 bar and MAX. 8 bar.
Function: 5/2 WAYS and 3/2 WAYS.
Available connections: 24V AC/DC, 110V AC and 220V A
Options: Namur, not Namur, Eexi, Eexd



Caja final de carrera / Sensor box

Material caja: Aleación de aluminio recubierto con poliéster y eje de acero inoxidable.
Protección: IP-67.
Temperatura: -20°C + 80°C.
Regleta de conexiones: 8 bornes y posibilidad de conexión 2 Finales de carrera +Electroválvula.
Indicador de posición: Abierto y cerrado de gran visibilidad.

Box material: Aluminium alloy covered with polyester and stainless steel shaft.
Protection: IP-67 Ambient
Temperature: -20°C + 80°C
Terminal connections: 8 terminal connections allowing 2 Limit switches + Solenoid Valve
Position indicator: Clearly visible open or closed indication

TWIN FERRULE FITTINGS

El anillo trasero proporciona una fuerte presión mecánica y anti-vibración en el tubo.
The back ferrule provides a strong mechanical and anti-vibration hold on the tube.

L' anell posterior proporciona una forta pressió mecànica i anti-vibració en el tub.

Sellado por presión mediante el anillo anterior.
Pressure seal by front ferrule on tube and body.

Segellat per pressió mitjançant anell anterior.

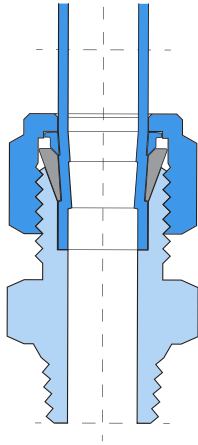

De paso fino, plateado de las roscas de la tuerca aseguran no griparse.
Fine pitch, silver plated nut threads ensure no galling.

De pas fi, platejat de les rosques de la femella asseguren no gripar.

Profundidad del tubo con tolerancia limitada entre la tuerca y el cuerpo para una correcta alineación del tubo.
Deep tube abutment and close tolerance of nut and body for accurate tube alignment.

Profunditat del tub amb tolerància limitada entre la femella i el cos per a una correcta alineació del tub.

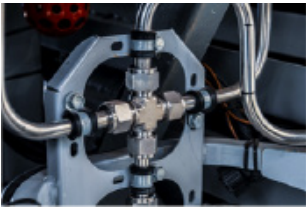

TEMPERATURA DE TRABAJO

Los accesorios Redfluid en acero inoxidable 316 ofrecen un rendimiento altamente fiable desde temperaturas de Criogenización, a niveles altos de temperatura. Pueden trabajar desde -196°C a +649 ° C.

La presión de trabajo es función de la temperatura.

Para determinar la presión de trabajo a una temperatura específica, multiplique la presión de trabajo a temperatura ambiente que se muestra en la tabla por el factor se muestra en la tabla siguiente:

RATING TEMPERATURE

Redfluid fittings in Stainless Steel 316 provide highly reliable performance from cryogenic temperature to high temperature levels. SS316 Stainless Steel Temperature Rating from -196°C to + 649 °C.

The allowable working pressure is determined by various temperatures. To determine the working pressure at the specific temperature, multiply the working pressure at ambient temperatures shown in table by the factor shown the below table.

TEMPERATURA DE TREBALL

Els accessoris Redfluid en acer inoxidable 316 ofereixen un rendiment altament i fiable a temperatures de criogenització i altes temperatures. Poden treballar des de -196 ° C a +649°C.

La pressió de treball en servei és funció de la temperatura.

Per determinar la pressió de treball de una temperatura concreta, multipliqui la pressió de treball a temperatura ambient que es mostra a la taula de pressions de treball pel factor es mostra a la següent taula.

FACTOR DE TEMPERATURA DE TRABAJO RATING TEMPERATURE FACTORS FACTOR DE TEMPERATURA DE TREBALL

Stainless Steel 316/ 316L		
Temperature		Correction factor
°F	°C	
100	37	1.00
200	93	1.00
300	148	1.00
400	204	0.93
500	260	0.87
600	315	0.82
700	370	0.80
800	426	0.76
900	480	0.73
1000	537	0.69
1200	649	0.30







CLASIFICACIONES DE TEMPERATURA DEL TUBO RATING TEMPERATURE TUBING CLASSIFICACIONES DE TEMPERATURA DEL TUB

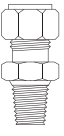

Las temperaturas máximas y mínimas para diferentes materiales del tubo.
The maximum and minimum operating temperatures for various tubing material.
Les temperatures màximes i mínimes per diferents materials del tub.

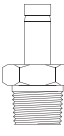

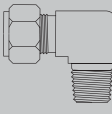
TUBING MATERIAL	TEMPERATURE RANGE
Stainless steel 316	-321 °F to 1200 °F (-196 °C to 649 °C)
Carbon Steel	-65 °F to 799 °F (-53 °C to 426 °C)
Copper	-40 °F to 400 °F (-40 °C to 205 °C)
Alloy 400	-324 °F to 800 °F (-198 °C to 427 °C)
Alloy C276	-320 °F to 1000 °F (-195°C to 537 °C)
Alloy 600	-205 °F to 1200 °F (-130 °C to 648 °C)
Titanium	-320 °F to 600 °F (-195 °C to 315 °C)
Teflon	0° F to 150 °F (-17 °C to 65 °C)

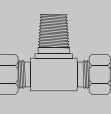
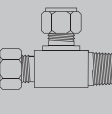

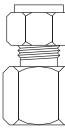
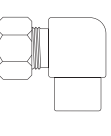
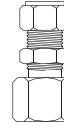

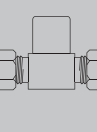
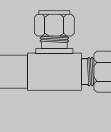
HIDRÓGENO / HYDROGEN / HIDROGEN

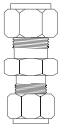
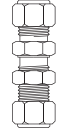
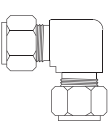
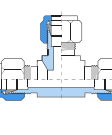
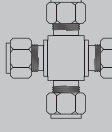

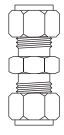

RACORES DE DOBLE ANILLO / TWIN FERRULE FITTINGS / RÀCORDS DE DOBLE ANELL

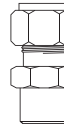
TUBO A ROSCA MACHO TUBE TO MALE THREAD <i>TUB A ROSCA MASCLE</i>	MALE CONNECTOR Page 8		MALE STRAIGHT Page 8		MALE ADAPTER Page 9		MALE ADAPTER Page 9	
	MALE ELBOW Page 10		BULKHEAD MALE CONNECTOR Page 10-11		MALE BRANCH TEE Page 11		MALE RUN TEE Page 11	
NPT BSPT BSPP								

TUBO A ROSCA HEMBRA TUBE FEMALE THREAD <i>TUB A ROSCA FEMELLA</i>	FAMELE CONNECTOR Page 12		FAMELE CONECTOR GAUGE Page 12		FAMELE ELBOW Page 13		BULKHEAD FAMELE CONNECTOR Page 13-14	
	FAMELE ADAPTER Page 14		FAMELE BRANCH TEE Page 15		FAMELE RUN TEE Page 15-16			
NPT BSPT BSPP								

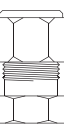
TUBO A TUBO TUBE-TUBE CONNECTOR <i>TUB A TUB</i>	UNION Page 17		BULKHEAD Page 16		UNION ELBOW Page 16		UNION TEE Page 16	
	UNION CROSS Page 16		BULKHEAD REDUCER Page 17					
NPT BSPT BSPP								

TUBO A TUBO CON REDUCCIÓN TUBE CONNECTOR REDUCED <i>TUB A TUB AMB REDUCCIÓ</i> NPT / BSPT / BSPP	REDUCING UNION Page 17		MALE PIPE WELD CONNECTOR Page 17		SW TUBE CONNECTOR Page 17		REDUCER / REDUCER MIXTE Page 18	

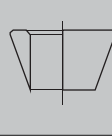
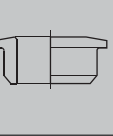
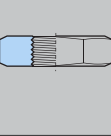
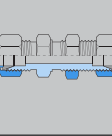
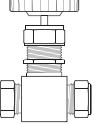
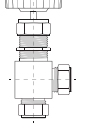
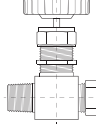
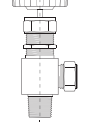
ACCESORIOS Y VALVULAS ACCESSORIES <i>ACCESSORIS / VALVUL-LES</i> NPT BSPT BSPP	CAP Page 19		PLUG Page 19		TUBE INSERT Page 20		NUT Page 20	
	FRONT FERRULE Page 20		BACK FERRULE Page 20		BULKHEAD LOKNUT Page 20		DIELECTRIC UNION Page 21	
	VALVULA MINOR Page 23		VALVULA MINOR Page 23		VALVULA MINOR Page 24		VALVULA MINOR Page 24	

CONE & THREAD FITTINGS

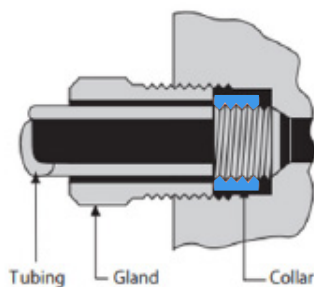

High-Pressure Adapter

REDFLUID High-Pressure fittings seal with a 60-degree cone and are rated for working pressures up to 4.140 bar/ 60.000 psi



Common Description	Actual Thread Dimension
1/4" High Pressure	9/16"x18UNF
3/8" High Pressure	3/4"x16UNF
9/16" High Pressure	1 1/8"x12UNF

Medium-Pressure Adapter

REDFLUID Medium-Pressure fittings seal with a 60-degree cone and are rated for working pressures up to 20.000 psi.



Common Description	Actual Thread Dimension
1/4" Medium Pressure	7/16"x20UNF
3/8" Medium Pressure	9/16"x18UNF
9/16" Medium Pressure	1 3/16"x16UNF
3/4" Medium Pressure	3/4" x 14 NPSM
1" Medium Pressure	1 3/8"-12 UNF

JIC Adapter

REDFLUID JIC adapters seal with a 37-degree cone and are rated for working pressure up to 15.000 psi



Common Description	Working Pressure
#4 #6 #8	1.035 bar / 15.000 psi
#12 #16	690 bar / 10.000 psi
Common Description	Actual Thread Dimension
#4 1/4" JIC	7/16"x20UNF
#6 3/8" JIC	9/16"x18UNF
#8 1/2" JIC	3/4"x16UNF
#12 3/4" JIC	1 1/16"x12UNF
#16 1" JIC	1 5/16"x12UNF

NPT Adapter

NPT (National Pipe Taper) fittings have working pressures up to 1.035 bar/ 15.000 psi. However, working pressure may be decreased depending upon thread size.



Common Description	Working Pressure
1/16" NPT bis 1/2"NPT	1.034 bar / 15.000 psi
3/4"NPT bis 1" NPT	690 bar / 10.000 psi

Type-M Adapter

REDFLUID Type M adapters are used with Type M swivel hose end fittings. These adapters seal with a 58 degree cone and are rated for working pressures up to 3.450 bar/50.000 psi.



Common Description	Actual Thread Dimension
M9	9/16"x18UNF
M12	3/4"x16UNF
M14	7/8"x14UNF
M16	1"x12UNF
M18	1 1/8"x12UNF
M21	1 5/16"x12UNF

Metric adapter

REDFLUID metric adapters (for o-rings) seal with a 24 degree cone



Common Description	Actual Thread Dimension
MEM18 MEF18	M18x1,5
MEM20 MEF20	M20x1,5
MEM22 MEF22	M22x1,5
MEM24 MEF24	M24x1,5
MEM26 MEF26	M26x1,5
MEM30 MEF30	M30x2
MEM36 MEF36	M36x2
MEM42 MEF42	M42x2

BSPP Adapter

REDFLUID BSPP adapters are used with Type M swivel hose end fittings. These adapters seal with a 58 degree cone and are rated for working pressures up to 3.450 bar/50.000 psi.



Common Description	Cone Dimension
Ext	120° external sealing cone
Int	60° internal sealing cone

SECCIÓN D / SECTION D / SECCIÓ D

ACCESORIOS 3000 Y 6000 PSI / PIPE FITTINGS 3000 & 6000 PSI / ACCESSORIS 3000 I 6000 PSI



Los accesorios se fabrican en Acero forjado o laminado, de acuerdo con la norma ANSI B.16.11.

- Rosca NPT (ANSI B.2.1.)
- S.W. (ANSI B.16.11.)
- ROSCA GAS cónica BSPT (DIN-2999)

Presión Nominal:
3.000 Lbs. (219 Kg/cm²)
6.000 Lbs. (414 kg/cm²)

MATERIALES

- Acero al carbono ASTM-A 105 Gr. II
- Acero inoxidable (AISI-316/316L)
- Duplex, Superduplex.
- F1, F11, F22, F91.

The fittings are made of forged or bar steel, according ANSI B.16.11. standard.

- NPT (ANSI B.2.1.)
- S. W. (ANSI B.16.11.)
- GAS tapered BSPT THREAD (DIN-2999)

Pressure Rating:
3.000 Lbs. (219 Kg/cm²)
6.000 Lbs. (414 Kg/ cm²)

MATERIALS

- Carbon Steel ASTM A 105 Gr-II
- Stainless steel (AISI-316/316L)
- Duplex, superduplex.
- F1, F11, F22, F91.

Els accessoris es fabriquen en Acer forjat o laminat, d'acord amb la norma ANSI B.16.11.

- Rosca NPT (ANSI B.2.1.)
- S.W. (ANSI B.16.11.)
- ROSCA GAS cónica BSPT (DIN-2999)

Pressió Nominal:
3.000 Lbs. (219 Kg/cm²)
6.000 Lbs (414 Kg/cm²)

MATERIALS

- Acer al carboni ASTM-A 105 Gr. II
- Acer inoxidable (AISI-316/316L)
- Duplex, superduplex.
- F1, F11, F22, F91.

Las bridas y fittings de Redfluid ofrecen tranquilidad en tu instalación de tuberías. Productos testados 100% con material verificado con PMI (Niton). Uno por uno se verifica que el material entregado cumpla con las características químicas y mecánicas del estándar solicitado.

Redfluid flanges and fittings offer peace of mind in your pipe installation. Products 100% tested with material verified with PMI(Niton). One by one it is verified that the delivered material complies with the chemical and mechanical characteristics of the requested standard

Les brides i fittings de Redfluidofrecen tranquil·litat en la teva instal·lació de canonades. Productostestats100% amb material verificat amb PMI (Niton). Un porú es verifica que el material lliurat complixi amb les característiques químiques imecàniques de l'estàndard sol·licitat.

Adaptadores, fittings, bridas o Racores de diferentes conexiones y medidas para conectarse a todo tipo de roscas y tipologías de conexión.

Adapters, fittings, flanges or fittings of different connections and sizes to connect to all types of fittings and connection types.

Adaptadors, fittings, brides o Racors de diferents connexions i mesures per connectar-se a tot tipus de poders i tipologies de connexió.



















REDFLUID puede suministrar accesorios en dimensiones, roscas, figuras o materiales no especificados en el presente catálogo. Atendemos cualquier petición en plazos de entrega mínimos. CONSÚLTENOS. info@redfluid.es

REDFLUID dimensions can supply accessories, threads, figures, dimensions or materials not specified in this catalog. ASK US. info@redfluid.es









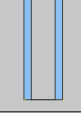
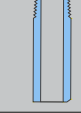
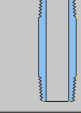
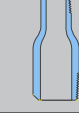
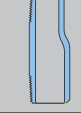



REDFLUID pot subministrar accessoris en dimensions, rosques, figures o materials no especificats en el present catàleg. Atenem qualsevol petició en terminis de lliurament mínims. CONSULTI'NS. info@redfluid.es





ÍNDICE DE FIGURAS/ FIGUES TABLE / ÍNDEX DE FIGURES



ACCESORIOS 3000 Y 6000 PSI / PIPE FITTINGS 3000 & 6000 PSI / ACCESSORIS 3000 I 6000 PSI

THREADED FITTINGS	90° ELBOW Page 5		TEE Page 5		CROSS Page 5		45° ELBOW Page 6		STREET ELBOW Page 6	
	COUPLING Page 7		CAP Page 7		HALF COUPLING Page 7		REDUCING COUPLING Page 7		HEX HEAD BUSHING Page 8	
	HEX HEAD PLUG Page 8		SQUARE HEAD PLUG Page 8		ROUND HEAD PLUG Page 8		UNION Page 9		M/F UNION Page 9	
	HEX NIPPLE Page 10		REDUCING HEX NIPPLE Page 10		FEMALE MALE REDUCER Page 10					

THREADED SOCKET WELDING FITTINGS	PIPE NIPPLE PE Page 11		HALF PIPE NIPPLE TOE Page 11		PIPE NIPPLE TBE Page 11		SWAGE NIPPLE Page 12		ECCENTRIC SWAGE NIPPLE Page 12	
-----------------------------------------	---------------------------	------------------------------------------------------------------------------------	---------------------------------	------------------------------------------------------------------------------------	----------------------------	------------------------------------------------------------------------------------	-------------------------	--------------------------------------------------------------------------------------	-----------------------------------	--------------------------------------------------------------------------------------

SOCKET WELDING FITTINGS	90° ELBOW Page 13		TEE Page 13		CRUZ Page 14		45° ELBOW Page 14		COUPLING Page 15	
	REDUCING COUPLING Page 15		HALF COUPLING Page 15		CAP Page 15		UNION Page 16		M/F UNION Page 16	
	REDUCER INSERT TYPE 1 Page 17		REDUCER INSERT TYPE 2 Page 17		REDUCER INSERT TYPE 3 Page 17					

THREADED AND SOCKET WELDING FITTINGS	BOSS Page 18		BOSS Page 18		SOCKET BRANCH Page 19		THREADED BRANCH Page 19	
---------------------------------------------	-----------------	-------------------------------------------------------------------------------------	-----------------	-------------------------------------------------------------------------------------	--------------------------	-------------------------------------------------------------------------------------	----------------------------	---------------------------------------------------------------------------------------

REINFORCED BUTT WELDING OUTLETS	WELD BRANCHE STD-XS Page 20		WELD BRANCHE 160-XXS Page 20	
----------------------------------------	--------------------------------	-------------------------------------------------------------------------------------	---------------------------------	-------------------------------------------------------------------------------------

THREADED, SW AND BW FITTINGS



SOCKET WELDING FITTINGS	90° ELBOW		TEE		CRUZ		45° ELBOW		COUPLING	
	Page 13		Page 13		Page 14		Page 14		Page 15	
	REDUCING COUPLING		HALF COUPLING		CAP		UNION		M/F UNION	
	Page 15		Page 15		Page 15		Page 16		Page 16	
	REDUCER INSERT TYPE 1		REDUCER INSERT TYPE 2		REDUCER INSERT TYPE 3					
	Page 17		Page 17		Page 17					

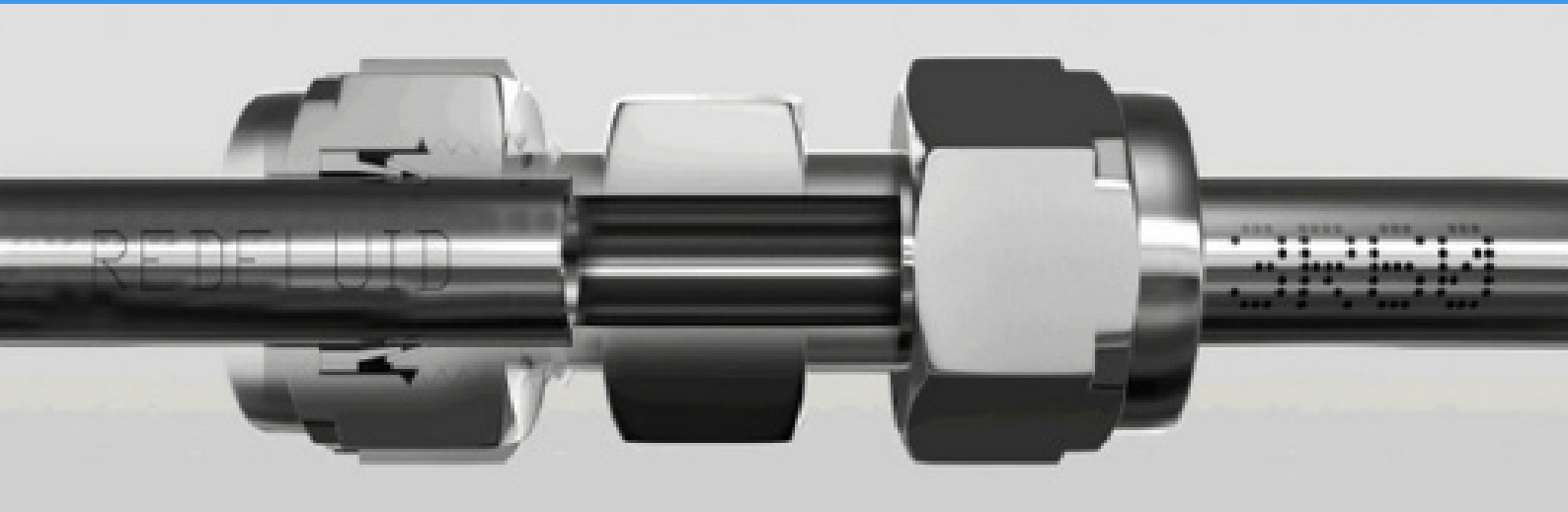

TUBE

TECHNICAL DATA

STANDARD LENGTH	6M
TUBING TYPES	High Pressure, Medium Pressure
MATERIAL	316 Stainless Steeressurel
MAX WORKING PRESSURE	4.140 bar // 60.000 psi
TEMPERATURE	-252°C bis +649°C



The high-pressure tubing made by REDFLUID, which can be used in pressure ranges of up to 4,140 bar / 60,000 psi, has a standard length of 6 m. It is seamless-drawn from stainless steel, thanks to which it achieves its high quality and safety. Besides the standard lengths, REDFLUID also offers the tubing cut to shorter lengths.

Size	Max working pressure		OD	ID	Wall Thickness	Weight	TOLERANCES			
							Max. OD	Min. OD	Max. ID	Min. ID
INCH	BAR	PSI	mm	mm	mm	kg/m	mm	mm	mm	mm
1/4"	1.380	20.000	6.35	2.77	1.79	0.21	6.30	6.17	2.77	2.64
1/4"	4.140	60.000	6.35	2.11	2.12	0.23	6.30	6.17	2.11	2.01
3/8"	1.380	20.000	9.53	5.16	2.18	0.4	9.40	9.27	5.16	5.03
3/8"	4.140	60.000	9.53	3.18	3.18	0.51	9.40	9.27	3.18	3.07
9/16"	1.380	20.000	14.29	7.92	3.18	0.89	14.15	14.02	7.92	7.80
9/16"	4.140	60.000	14.29	4.78	4.76	1.14	14.15	14.02	4.75	4.62
3/4"	1.380	20.000	19.05	11.13	3.96	1.5	18.92	18.80	11.13	10.97
1"	1.380	20.000	25.4	14.27	5.56	2.77	25.27	25.15	14.27	14.15

SUGGESTED ALLOWABLE WORKING PRESSURE

TUBE OD mm	TUBE WALL THICKNESS MM													
	0.6	1.0	1.2	1.5	1.8	2.0	2.2	2.5	2.8	3.0	3.5	4.0	4.5	5.0
WORKING PRESSURE, bar														
3	679													
6	310	420	540	710										
8		310	390	520										
10		240	300	400	510	580								
12		200	250	330	410	470								
14		160	200	270	340	380	430							
15		15	190	250	310	360	400							
16			170	230	290	330	370	400						
18			150	200	260	290	320	370						
20			140	180	230	260	290	330	380					
22			140	160	200	230	260	300	340					
25					180	200	230	260	290	320				
28						180	200	230	260	280	330			
30						170	180	210	240	260	310			
32						160	170	200	220	240	290	330		
38							140	160	190	200	240	270	310	
50										150	180	210	240	270

* Rating based on pressure test with hydraulic fluid leakage with a 2:1 design factor. Figures shown in our catalogue are not for design purpose but reference only and the accuracy of information is not liability of our company. Please contact our engineers for calculations for your own project. Gas service can have very small molecules and can escape through minute leak path due to surface imperfections. For gas service higher wall thickness has to be considered.

SELECCIÓN DEL TUBO

Recomendamos utilizar tubos recocidos sin soldadura. Una menor dureza con respecto a los anillos facilita un mejor cierre.

Los tubos deben tener un acabado superficial idóneo, deben ser lisos, sin rebabas ni arañazos u otros defectos superficiales que puedan perjudicar el cierre.

En tubería con soldadura recomendamos utilizar tubería con tolerancias según EN ISO 1127:D4/T3. Cuando se utiliza tubo con soldadura, se debe aplicar un coeficiente de 0.8 para determinar la presión de servicio según ASME B31.3.

Desestimar tubos ovalados o deformados que no pasen fácilmente a través de la tuercas, anillos y cuerpos de los racores.

SELECTION OF TUBE

We recommend using annealed seamless tubes. A lower hardness with respect to the rings provides a better seal.

The tubes must have a suitable surface finish should be smooth without burrs or other surface defects that can perjudicar closing.

In welded stainless steel tubing we recommend using tolerances to EN ISO 1127: D4/T3. Based on ASME B31.3 for weld integrity a de-rating factor of 0.8 must be applied to welded tubing pressure rating.

Reject tubes deformed oval or not easily pass through the nuts, rings, and the fittings.

SELECCIÓ DEL TUB

Recomanem utilitzar tubs sense soldadura. Si tenen una menor duresa respecte als anells facilita un millor tancament.

Els tubs han de tenir un acabat superficial idoni, han de ser llisos, sense rebaves ni esgrapades o altres defectes superficials que puguin perjudicar el tancament.

En tuberia amb soldadura recomanem utilitzar toleràncies segons EN ISO1127: D4/T3. Un factor de 0.8 té que ser aplicat per determinar la presió màxima de servei segons ASME B31.3. Desestimar tubs ovalats o deformats on no passin fàcilment a les femelles, anells i cossos dels racords.

HIDRÓGENO / HYDROGEN / HIDROGEN

TUBO DE ALTA PRESIÓN / HIGH-PRESSURE TUBING / TUB D'ALTA PRESSIÓ

El tubo de alta presión redfluid, que puede utilizarse en rangos de presión de hasta 4,140 bar/60,000 psi, se presenta en una longitud estándar de 6 metros. Este tubo se fabrica de manera continua a partir de acero inoxidable, garantizando así su alta calidad y seguridad. Además de la longitud estándar, redfluid también ofrece la opción de cortar el tubo a longitudes más cortas. Si es necesario, el tubo también puede suministrarse conificado en longitudes personalizadas apto para rácores cone & thread.

The redfluid high-pressure tubing, suitable for pressure ranges of up to 4,140 bar/60,000 psi, comes in a standard 6m length. This tubing is seamlessly drawn from stainless steel, ensuring both high quality and safety. In addition to the standard length, redfluid also offers the option of cutting the tubing to shorter lengths. If necessary, the tubing can also be provided with custom lengths and cone & thread ends ready for cone & thread fittings.

El tub redfluid d'alta pressió, adequat per a rangs de pressió de fins a 4.140 bar/60.000 psi, té una longitud estàndard de 6 metres. Aquest tub està dibuixat de manera contínua amb acer inoxidable, assegurant-ne la seva alta qualitat i seguretat. A més de la longitud estàndard, redfluid també ofereix l'opció de tallar el tub a longituds més curtes. Si és necessari, el tub també pot proporcionar-se amb longituds concretes i ja conifícat per racords "cone & thread".

TECHNICAL DATA FOR HYDROGEN HIGH PRESSURE TUBING

STANDARD LENGTH	6M
TUBING TYPES	High Pressure Medium Pressure
MATERIAL	316 Stainless Steel
MAX WORKING PRESSURE	4.140 bar // 60.000 psi
TEMPERATURE	-252°C bis +649°C
FINISH	SMLS tube cold drawn hard pickled
OPTIONALS	Clean & Degreased for H2 Service Cone & Thread Ends Custom Lengths



Size	Max working pressure		OD	ID	Wall Thickness	Weight	TOLERANCES			
							Max. OD	Min. OD	Max. ID	Min. ID
INCH	BAR	PSI	mm	mm	mm	kg/m	mm	mm	mm	mm
1/4"	1.380	20.000	6.35	2.77	1.79	0.21	6.30	6.17	2.77	2.64
1/4"	4.140	60.000	6.35	2.11	2.12	0.23	6.30	6.17	2.11	2.01
3/8"	1.380	20.000	9.53	5.16	2.18	0.4	9.40	9.27	5.16	5.03
3/8"	4.140	60.000	9.53	3.18	3.18	0.51	9.40	9.27	3.18	3.07
9/16"	1.380	20.000	14.29	7.92	3.18	0.89	14.15	14.02	7.92	7.80
9/16"	4.140	60.000	14.29	4.78	4.76	1.14	14.15	14.02	4.75	4.62
3/4"	1.380	20.000	19.05	11.13	3.96	1.5	18.92	18.80	11.13	10.97
1"	1.380	20.000	25.4	14.27	5.56	2.77	25.27	25.15	14.27	14.15



Pol. Ind. "Els Bellots"
C/ del Foc, 5, nave 5 - 08227 Terrassa - Barcelona
Tel (+34) 93 785 75 66 | Fax (+34) 93 785 31 97
Mail info@redfluid.es
www.redfluid.es